

iSPS-X-P11

Multi-parameter Water Quality Measurement Instrument Datasheet



Product overview

The iSPS-X Multi-parameter water quality probes is an online measuring instrument integrating pH/ORP, conductivity, TDS, salinity, turbidity, suspended solids, chlorophyll a, cyanobacteria, COD, dissolved oxygen (DO), TOC, nitrite nitrogen, free chlorine, ammonia nitrogen, fluoride, chloride, calcium ions, oil in water, and temperature. The iSPS-X can accommodate up to eight probes. Each probe employs distinct electrochemical, optical, or physical detection methods to measure its respective parameter. Users may read measurement data via a handheld device or transmit data to a data acquisition platform through a data logger.

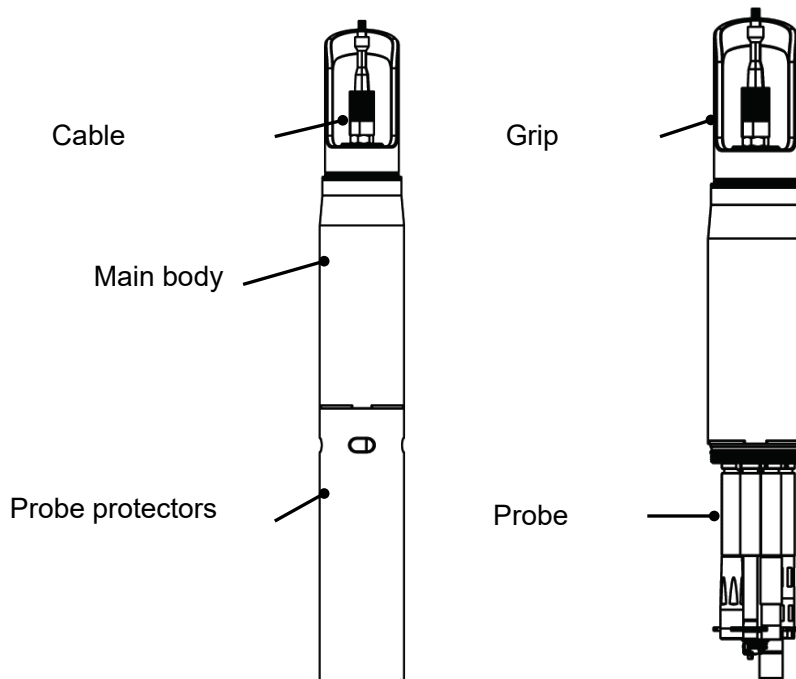

Application scenarios

- Monitoring of water in and out of sewage treatment plant
- Water quality monitoring in the treatment process of the sewage treatment plant
- Water quality monitoring of urban pipe network
- Surface water, groundwater monitoring
- Tap water and pipe network monitoring
- Sea water

Advantages

- Fast measurement, fastest measurement cycle of 10 second
- No reagent consumption, environmentally friendly
- With cleaning brushes, long maintenance-free intervals
- RS485 communication for fast connection to meter controller
- IP68 protection for harsh environments
- Multi-parameter all-in-one, compact size and high integration

Principle

Parameter	Principle
pH	Glass electrode method
ORP	Glass electrode method
K ⁺	Ion-selective electrode method
NH ₃ -N/NH ₄ ⁺	Ion-selective electrode method
Chloride	Ion-selective electrode method
Fluoride	Ion-selective electrode method
Calcium	Ion-selective electrode method
EC	Parallel 4 graphite electrode method
TDS	Parallel 4 graphite electrode method
Salinity	Parallel 4 graphite electrode method
DO	Fluorescence method
Turbidity	Transmission and 90° scattering (ASM002776)
	Transmission (ASM002777)
COD	Ultraviolet absorption spectroscopy
TOC	Ultraviolet absorption spectroscopy
DOC	Ultraviolet absorption spectroscopy
BOD	Ultraviolet absorption spectroscopy
SAC 254	Ultraviolet absorption spectroscopy
TSS	Transmission
	Ultraviolet spectral absorption method (ASM002777)
NO ₃ -N/NO ₃ ⁻	Ion selective electrode (ISE) method (ASM002831)
Chlorophyll-a	Fluorescence method
Phycocyanin (PC)	Fluorescence method
Phycocerythrin (PE)	Fluorescence method
Rhodamine (Rh)	Fluorescence method
Fluorescent dissolved organic matter (fDOM)	Fluorescence method
Uranine (UR, Fluorescein sodium)	Fluorescence method
Oil in water (OIW)	Fluorescence method
Polycyclic aromatic hydrocarbons (PAH)	Fluorescence method
Temperature	PT1000

Specification

Parameter	Detail
Dimensions	Φ80×622 mm
Weight	2.5 Kg (With probe)
IP rating	IP68

Installation	Submerged
Power requirements	12 -24 VDC
Battery	18650 lithium battery (3.7 V) × 4
Power consumption	<12 W (With battery), <6 W (Without battery)
Cable length	Customized cable lengths ¹
Depth	Maximum depth 100 m
Main body materials	Poly-ether-ether-ketone (PEEK)
Measurement cycle	10 seconds, adjustable
Cleaning method	Wiper ²
Operating temperature	-5 to 50 °C
Storage temperature	-5 to 50 °C
Hardware Interface	RS485
Storage space	32 GB
Wired communication	Modbus RTU
Wireless communication	Bluetooth, WiFi
Warranty	1 year (Only the main body is guaranteed for one year, the probe warranty period is detailed in the table above.)

1 The length of the cable will not change after customization, please confirm the length before ordering, and we will charge according to the length of the cable.

2 The cleaning wiper is a separate accessory, if you need it, please tell the sales staff before ordering

Parameter information

Parameter	Model No.	Range	Resolution	Accuracy (Standard solution)
pH	ASM002820 ASM002946 ¹	0-14	0.01	±0.1
ORP	ASM002821 ASM002947 ²	-2000 mV to 2000 mV	1 mV	±20 mV
pH & ORP	ASM002772	0-14	0.01	±0.1
		-1500 mV to 1500 mV	1 mV	±20 mV
K ⁺	ASM002771	0-1000 mg/L	0.01 mg/L	±5% R.D. or ±0.5 mg/L
NH ₃ -N ³	ASM002770	0-1000 mg/L	0.01 mg/L	±5% R.D. or ±0.5 mg/L
NH ₄ ⁺		0-1200 mg/L	0.01 mg/L	±5% R.D. or ±1 mg/L
Chloride	ASM003090	0-1000 mg/L	0.01 mg/L	±5% R.D. or ±0.5 mg/L
Fluoride	ASM003088	0-1000 mg/L	0.01 mg/L	±5% R.D. or ±0.5 mg/L
Calcium	ASM003094	0-1000 mg/L	0.01 mg/L	±5% R.D. or ±0.5 mg/L
Conductivity	ASM002774	0-100 mS/cm	0.1 μS/cm	±5% R.D. or 1



				µS/cm
		100-200 mS/cm	0.01 mS/cm	±5% R.D.
Salinity		0-60 ppt	0.0001 ppt	±5% R.D. or 0.001 ppt
		60-120 ppt	0.01 ppt	±5% R.D.
TDS		0-50 g/L	0.1 mg/L	±5% R.D. or ±1 mg/L
		50-100 g/L	0.01 g/L	±5% R.D.
DO	ASM002775	0-20 mg/L	0.01 mg/L	±1% R.D. or ±0.1mg/L
		0-200%	0.1%	±1% R.D. or ±1% air sat
Turbidity	ASM002776	0-1000 NTU	0.001 NTU	±2% R.D. or ±0.3 NTU
		1000-4000 NTU	0.1 NTU	±5% R.D.
TSS		0-2000 mg/L	1 mg/L	±5% R.D. or ±5 mg/L
COD		0-500 mg/L	0.01 mg/L	±5% R.D. or ±5 mg/L
TOC		0-200 mg/L	0.01 mg/L	±5% R.D. or ±2 mg/L
NO ₃ -N		0-50 mg/L	0.01 mg/L	±5% R.D. or ±1 mg/L
NO ₃ ⁻⁴		0-200 mg/L	0.01 mg/L	±5% R.D. or ±5 mg/L
DOC	ASM002777	0-200 mg/L	0.01 mg/L	±5% R.D. or ±2 mg/L
BOD		0-300 mg/L	0.01 mg/L	±5% R.D. or ±3 mg/L
SAC254		0-500 Abs/m	0.01 Abs/m	±5% R.D. or ±2.5 Abs/m
Turbidity		0-500 NTU	0.01 NTU	±5% R.D. or ±5 NTU
TSS		0-500 mg/L	1 mg/L	±5% R.D. or ±5 mg/L
NO ₃ -N	ASM002831	0-200 mg/L	1 mg/L	±5% R.D. or ±1 mg/L
NO ₃ ⁻		0-850 mg/L	1 mg/L	±5% R.D. or ±5 mg/L
Chlorophyll-a	ASM003000	0-400 µg/L	0.01 µg/L	R ² >0.999
PC		0-100 µg/L	0.01 µg/L	R ² >0.999



PE		0-400 µg/L	0.01 µg/L	R ² >0.999
UR		0-500 µg/L	0.01 µg/L	R ² >0.999
Rh		0-400 µg/L	0.01 µg/L	R ² >0.999
fDOM		0-500 µg/L	0.02 µg/L	R ² >0.999
Oil in water	ASM002789	0-150 mg/L	0.01 mg/L	±5% R.D. or ±2% F.S.
PAH	ASM002789	0-5000 µg/L	0.1 µg/L	±5% R.D. or ±2% F.S.
Temperature	/	-5 to 50 °C	0.01 °C	±0.1 °C
Depth	Optional ⁵	0-10 m	0.001 m	±0.25% F.S. (±0.025 m)
		0-100m	0.002 m	±0.2% F.S. (±0.2 m)

1, 2: High pressure resistant version

3: Ammonia nitrogen (NH₃-N) is ammonium ions (NH₄⁺) expressed as nitrogen. They share a single register. If you require measurement in terms of ammonium ions (NH₄⁺) concentration, please contact our company

4: Nitrate nitrogen (NO₃-N) is nitrate (NO₃⁻) expressed as nitrogen. They share a single register. If you require measurement in terms of nitrate ion (NO₃⁻) concentration, please contact our company

5: Depths can be selected, and once selected, it cannot be changed.

6: F.S. = Full scale, R.D. = of reading.

Sensor pressure resistant

Name	Model No.	Pressure	Depth	Operating Temperature	Storage temperature
pH probe	ASM002820	<3 Bar	<30 m (98 feet)	-5 to 50 °C	0-50 °C
	ASM002946	<10 Bar	<100 m (328 feet)	-5 to 130 °C	0-50 °C
ORP probe	ASM002821	<3 Bar	<30 m (98 feet)	-5 to 50 °C	0-50 °C
	ASM002947	<10 Bar	<100 m (328 feet)	-5 to 130 °C	0-50 °C
pH & ORP probe	ASM002772	<3 Bar	<30 m (98 feet)	-5 to 50 °C	0-50 °C
K ⁺ probe	ASM002771	<1 Bar	<10 m (32.8 feet)	2-50 °C	0-50 °C
NH ₃ -N probe	ASM002770	<1 Bar	<10 m (32.8 feet)	2-50 °C	0-50 °C
Chloride probe	ASM003090	<1 Bar	<10 m (32.8 feet)	2-50 °C	0-50 °C
Fluoride probe	ASM003088	<1 Bar	<10 m (32.8 feet)	2-50 °C	0-50 °C



Calcium probe	ASM003094	<1 Bar	<10 m (32.8 feet)	2-50 °C	0-50 °C
Conductivity probe	ASM002774	<10 Bar	<100 m (328 feet)	-5 to 80 °C	-5 to 50 °C
DO probe	ASM002775	<6 Bar	<60 m (196.8 feet)	-5 to 50 °C	-5 to 50 °C
Turbidity probe	ASM002776	<10 Bar	<100 m (328 feet)	-5 to 50 °C	-5 to 50 °C
Multi-wavelength probe	ASM002777	<10 Bar	<100 m (328 feet)	-5 to 50 °C	-5 to 50 °C
NO ₃ -N probe	ASM002831	<1 Bar	<10 m (32.8 feet)	-5 to 50 °C	0-50 °C
Multi-channel fluorescence probe	ASM003000	<6 Bar	<60 m (196.8 feet)	-5 to 50 °C	-5 to 50 °C
Oil in water Probe	ASM002789	<6 Bar	<60 m (196.8 feet)	-5 to 50 °C	-5 to 50 °C

Probe maintenance intervals

Probe	Model	Life	Warranty	Calibration
pH probe	ASM002820	1-2 years	1 year	1-3 months
	ASM002946			
ORP probe	ASM002821	1-2 years	1 year	1-3 months
	ASM002947			
pH & ORP probe	ASM002772	1-2 years	1 year	1-3 months
Turbidity probe	ASM002776	3-5 years	1 year	2-3 months
NH ₃ -N probe	ASM002770	6 months	6 months	1-3 months
Chloride probe	ASM003090	6 months	6 months	1-3 months
Fluoride probe	ASM003088	6 months	6 months	1-3 months
Calcium probe	ASM003094	6 months	6 months	1-3 months
Conductivity probe	ASM002774	1-2 years	1 year	1-3 months
DO probe	ASM002775	3-5 years	1 year	2-3 months
K ⁺ probe	ASM002771	6 months	6 months	1-3 months
NO ₃ -N probe	ASM002831	6 months	6 months	1-3 months
Multi-wavelength probe	ASM002777	3-5 years	1 year	2-3 months
Multi-channel fluorescence probe	ASM003000	2-3 years	1 year	2-3 months
Oil in water Probe	ASM002789	2-3 years	1 year	2-3 months

Dimension

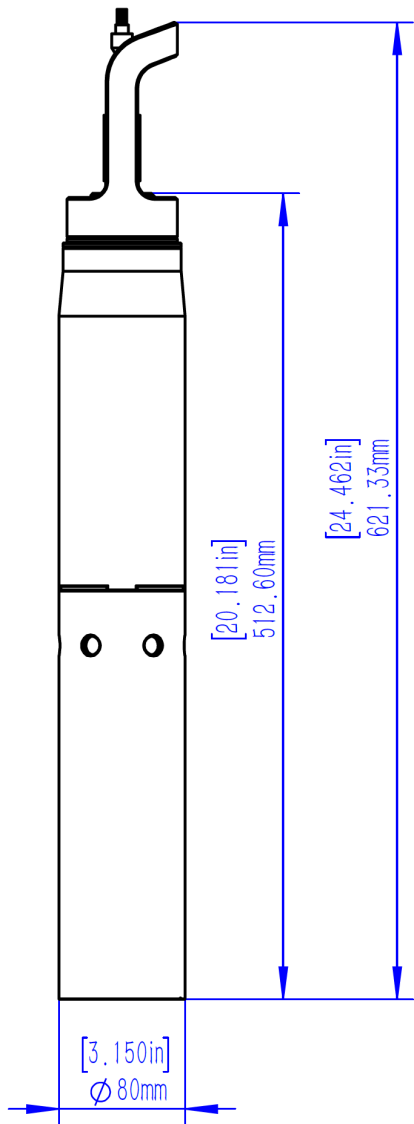

Product selection

Meter

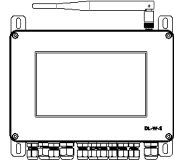

Meter controller
MC-W-S

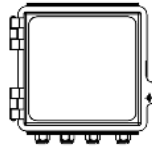

Meter controller
MC-BW-B

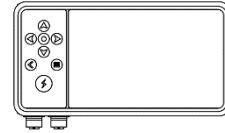

Meter controller
MC-HC

Customized cables

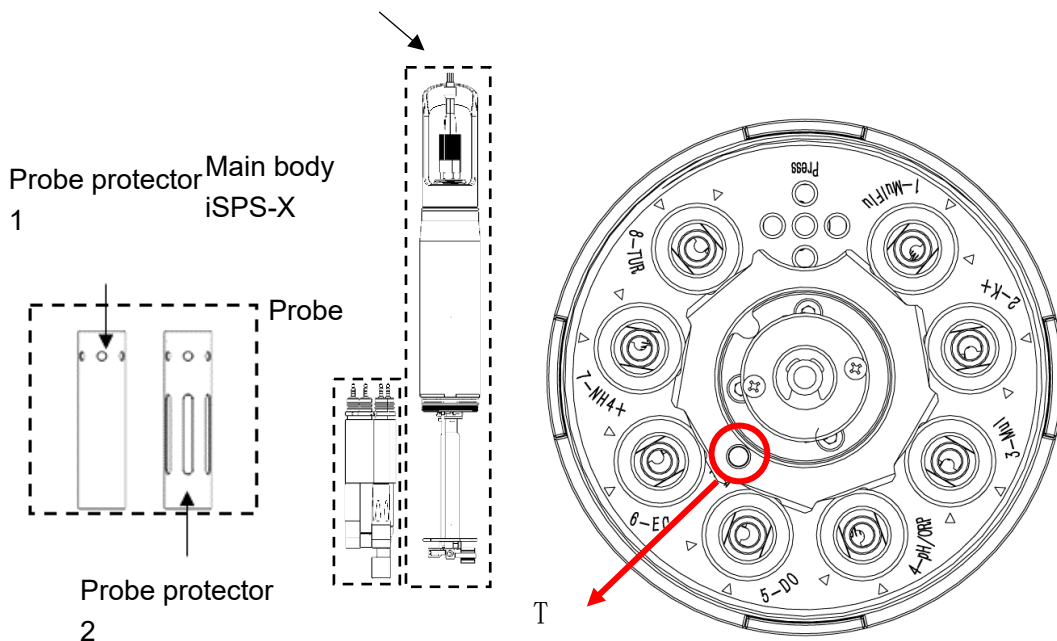

1	Port 1	2	Port 2	3	Port 3	4	Port 4
5	Port 5	6	Port 6	7	Port 7	8	Port 8
P	Pressure/depth	T	Temperature				

NOTICE

Probe protector 1: Excellent light-blocking properties. Probe protector 2: Good air permeability, relatively poor light-blocking properties. Use on shaded surfaces.

Meter	Main body	Sensor	Port	Material	Cleaning
Meter controller MC-HC Android OS 5" LCD support 4G, GIS, SD storage	Main body iSPS-X Include depth, pressure, temperature parameter	Muti channel fluorescence probe	Port 1	Titanium	Automatic cleaning
		K+ probe	Port 2	PVC+ PEEK	/
		NO3-N probe	Port 2/4/7	PVC+ PEEK	/
		Multi-wavelength spectrum probe	Port 3	Titanium	Automatic cleaning
		pH probe	Port 2/4/7	PVC+ PEEK	/
Meter controller MC-W-S Android OS 7" LCD support 4G/WiFi RS485 output, SD storage		ORP probe	Port 2/4/7	PVC+ PEEK	/
		pH & ORP probe	Port 4	PVC+ PEEK	/
		DO probe	Port 5	Titanium	Automatic cleaning
		EC probe	Port 6	PVC+ PEEK	Automatic cleaning
		NH3-N probe	Port 2/4/7	PVC+ PEEK	/
Meter controller MC-BW-B Android OS support Bluetooth 4G/WiFi, RS485 output SD storage		Chloride probe	Port 2/4/7	PVC+ PEEK	/
		Fluoride probe	Port 2/4/7	PVC+ PEEK	/
		Calcium probe	Port 2/4/7	PVC+ PEEK	/
		Oil in water probe	Port 1/3/8	Titanium	Automatic cleaning
		Turbidity probe	Port 8	Titanium	Automatic cleaning

Note:

1 The meter is selected according to the need, and the instrument cable is adjusted in length according to the need and charged accordingly.

2 Probes can only be connected to the corresponding sensor mounting position, and a mounting position can only be connected to one sensor, please according to the needs of a reasonable matching parameters. iSPS-X multi-parameter water quality probe can choose up to 8 water quality sensors.

Downhole Installation

Well-cellar, closed terrain mounting method

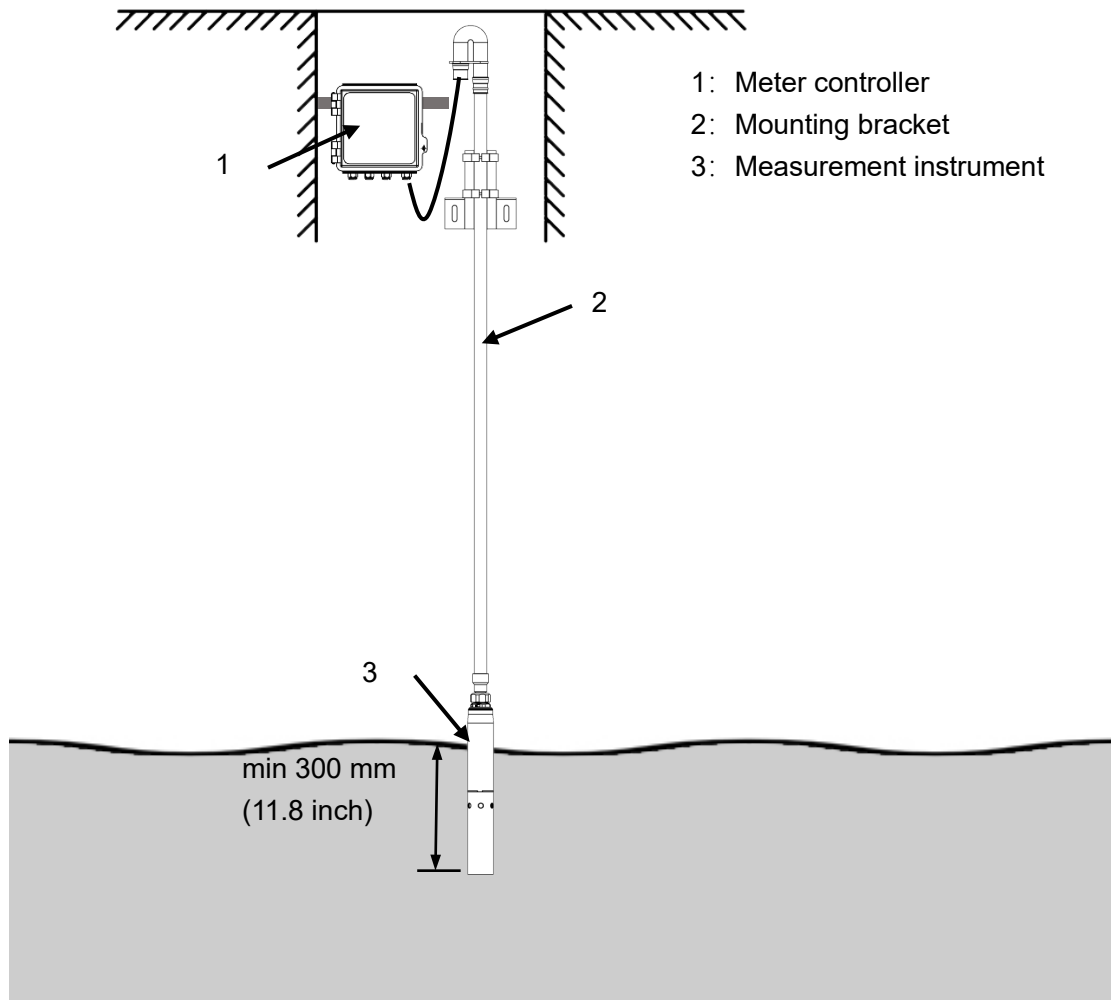

Well-cellar, closed terrain installation method

The items in the picture are only examples, please refer to the actual structure.

Recommended configuration

1	MC-BW-B meter controller (With Battery)
2	Mounting bracket
3	iSPS-X-P11 Measurement instrument



Open terrain installation

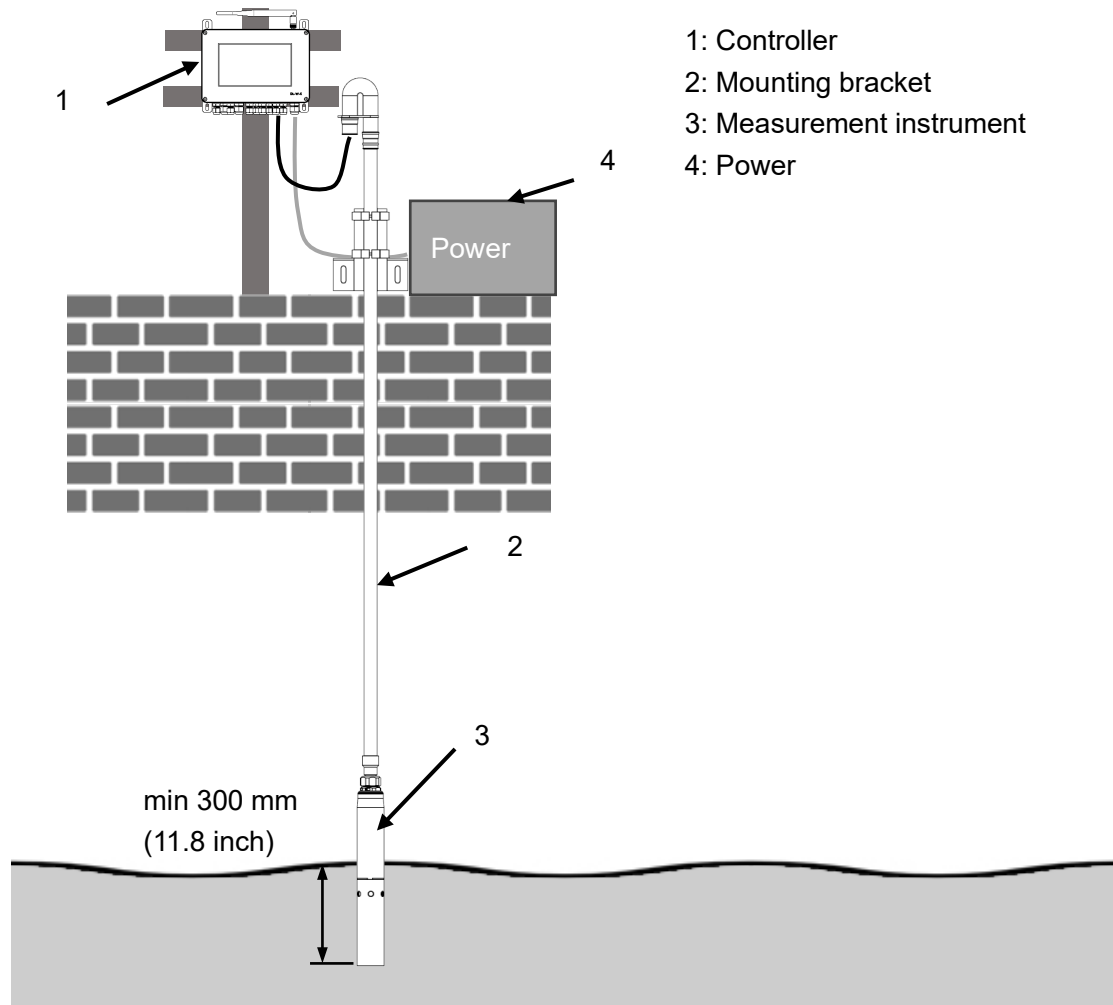

Open terrain installation

The items in the picture are only examples, please refer to the actual structure.

Recommended configuration

1	MC-W-S meter controller
2	Mounting bracket
3	iSPS-X-P11 Measurement instrument
4	24 V DC Power Supply

Handheld connection

Users can use the handheld MC-HC meter controller to connect to the iSPS-X measurement instrument, read the parameters of the iSPS-X, and also use the MC-HC to perform calibration and other operations. See MC-HC manual for detailed instructions. Users can also read and control the sensors by connecting to the sensors using an Android phone with our dedicated App. For more information, please refer to the App user manual.

Note: The Bluetooth connection distance cannot exceed 2 m and is not suitable for fully immersed connections.

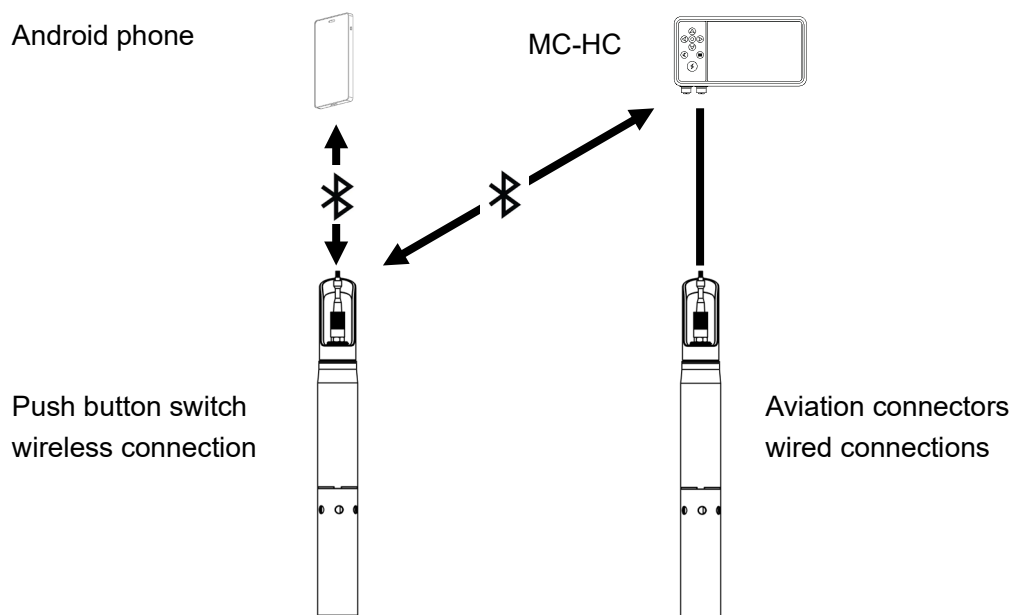

Wireless communication

The iSPS series supports AP mode, providing a WiFi hotspot for connection, and also supports STA mode for connecting to an existing WiFi network. Both AP mode and STA mode are enabled by default at the factory, allowing users to choose based on actual requirements.

After connecting via AP mode or STA mode, users can access the device by entering the corresponding address in a browser to perform actions such as reading data or controlling the device. For detailed instructions, refer to the iSens-Studio User Manual.

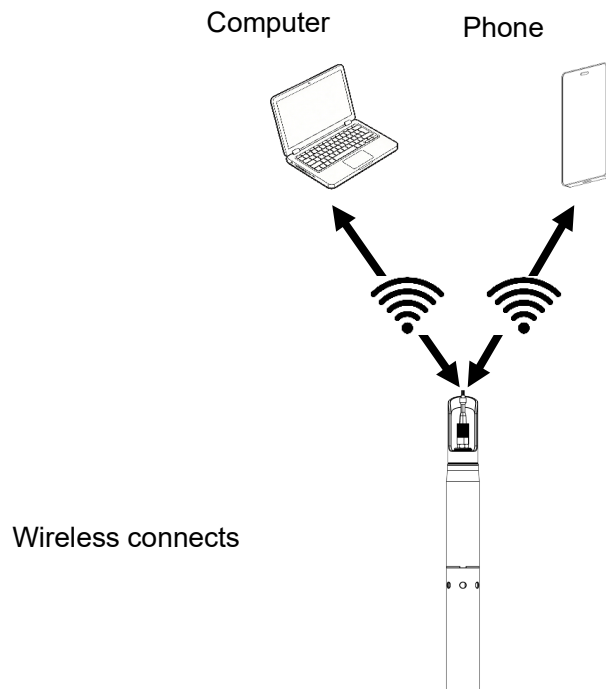

Automatic cleaning brush

When in use, the cleaning brush will rotate counterclockwise from the start position, rotate to the return position and then rotate clockwise back to the start position.

